

# Fault Diagnosis of CHB ML Inverter Using Wavelet Transform

Narendra Kumar Pal<sup>1</sup>, Radhika Vaishnav<sup>2</sup>  
<sup>1,2</sup>Department of EEE, MITS, Bhopal, India

*Abstract - Renewable energy has gained popularity due to depleting natural resources and escalating fossil fuel and nuclear pollution. Power electronic engineers design grid-connected power conversion systems. MLIs provide more power and solutions. Cascaded H-Bridge (CHB) MLIs start with two or more 3L single-phase H-bridge inverters. Each H-bridge may produce three separate voltage levels. Combining the separated dc voltage sources produces a stepped output voltage with a step size equal to the magnitude of the connected sources. The present work develops a method for detecting and resolving switch failures in a three-phase CHB inverter, ensuring system dependability and allowing for system redundancy. The recommended approach uses Wavelet transform to extract features, then Decision Tree classifier to detect and characterize defects. Increased classification accuracy shows the DT-based fault diagnosis system's efficiency in identifying inverter switch faults.*

*Keywords – Decision Tree, Discrete Wavelet transform, seven level Cascaded H-Bridge Inverter, Switch fault, fault diagnosis*

**How to cite this article:** Narendra Kumar Pal, Radhika Vaishnav, "Fault Diagnosis of CHB ML Inverter Using Wavelet Transform" Published in International Journal of Scientific Modern Research and Technology (IJS MRT), ISSN: 2582-8150, Volume-13, Issue-2, Number-1-6, November 2023, pp.1-8, URL: <https://www.ijsmrt.com/wp-content/uploads/2024/02/IJS MRT-23130201.pdf>

Copyright © 2023 by author (s) and International Journal of Scientific Modern Research and Technology Journal. This is an Open Access article distributed under the terms of the Creative Commons Attribution License (CC BY 4.0) (<http://creativecommons.org/licenses/by/4.0/>)



IJS MRT-23130201

## I. INTRODUCTION

In order to reduce the negative consequences of fossil fuel combustion, photovoltaics and wind resources are being employed as a complement to fossil fuel-based electric power production. [1]. It is anticipated that the bulk of these green power sources will be grid-interactive [2], which will allow for more efficient and dependable power extraction. Power electronic converters efficiently integrate scattered energy into the grid in this situation. [3-5]. Given that the utility system uses ac current, the incorporation of an inverter as a component of grid-connected renewable energy sources is unavoidable [6]. The IEEE std-512 (1992)

harmonic limit must be met since these inverters flip discretely, causing harmonics. Because reliable power transactions need these inverters, this compliance is necessary. As a consequence of this, the published research reveals a number of distinct changes in their structural configurations in order to conform to such rules [7]. However, many of these topologies require more filtering or a higher switching frequency to meet severe harmonic limits. In grid-integration, motor drives, traction, FACTS, HVDC, and many other disciplines, MLIs have replaced 2L inverters [8]. These drawbacks may be rectified.

Multilevel inverters (MLI) deliver improved power and solutions. A Cascaded H-Bridge (CHB) MLI is

created by connecting two or more 3L single-phase H-bridge inverters. Three voltage levels are possible per H-bridge. By merging the separated dc voltage sources, the output voltage is stepped with a step size equal to the magnitude of the connected dc sources [9].

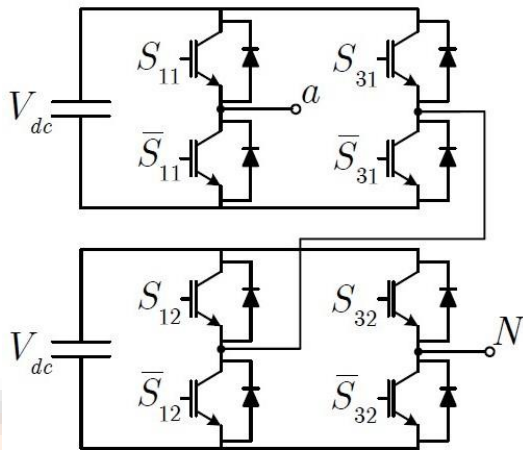

Figure 1: Neutral-point clamped (NPC).

Asymmetric MLIs, which use various capacitor voltages, have been popular recently. This concept emerged in the recent past. This idea has been effectively used to CHB MLI, despite the fact that the dc voltage of the H-bridges are not equal [10-12]. Additionally, it may be used for other MLI families as well [13]. Aside from the fact that the asymmetric MLI has differing capacitor voltages, the symmetric and asymmetric MLI are identical in terms of their physical construction. The main advantage of such an adjustment is creating more voltage levels with the similar number of components as a symmetric MLI. In addition, the term "hybrid MLI" refers to the combination of many MLIs, whether it be two of them together or simply a portion of one unique structure. In theory, there is an infinite number of ways in which these two things may be combined [14]. When placed together, the advantages of both topologies may be extracted, which is something that is not possible when studying them separately. This is made possible by the innovative arrangement described above.

## II. PROPOSED METHODOLOGY

In this part of the article, the 5-level NPC inverter is used to explain the suggested technique.

### A. Design and Simulation of 7-level CHB inverter topology

It is widely agreed upon that the most efficient topologies for usage with renewable energy sources are multilevel converters. Because of their high efficiency and performance levels in addition to their superior power quality, they are an attractive option for use. PV systems that are located on roofs and connected to the grid, it is essential to have power converters that are both extremely efficient and dependable. As a result of this, designs based on 7 layers of CHB topology inverters have been conceived of and put into practice within the sector.

### B. DWT based Feature Derivation

The wavelet transform is popular for extracting relevant information from data since it represents it in both the time and frequency domains. Because of its faster response time and shorter execution time, DWT is the more suitable option for online verification. [15][16]. DWT is able to differentiate between healthy and unhealthy conditions depending on the presence or absence of noise-reducing architectural elements as well as the appropriate level of accuracy and complexity. Because of its properties, DWT is well suited for the protection of transmission lines. The discrete wavelet transform (DWT) performs statistical analysis on sampled voltage and current data by applying high-pass and low-pass filters to time domain signals.

Wavelet Toolbox provides continuous and discrete wavelets. Orthogonal and B-spline biorthogonal wavelets for discrete analysis. Wavelet Toolbox provides Morlet, Meyer, Gaussian, and Paul wavelets for continuous analysis. The signal or picture and application determine the wavelet. If you are familiar with wavelet analysis and synthesis, you will have a better chance of selecting the best wavelet. Wavelet families have a number of characteristics that are important to image processing. Both symmetry and anti-symmetry of wavelets.

Filters with linear phase that are used in conjunction with full reconstruction. Moments that quickly go. Wavelets with a greater number of vanishing moments communicate messages and images in a less dense manner. The consistency of wavelets a higher

frequency resolution with wavelets that are less jagged. Iterative wavelet algorithms converge faster. scales. In order to analyze and synthesize wavelets in a continuous manner, the Wavelet Toolbox application employs Fourier transformations. Wavelets whose Fourier transformations are limited each have a single integral inverse. Rebuilding a time- and scale-localized input signal is now possible as a result of this. Changes need to be made to the raw data before compression can successfully reduce redundant and superfluous information. Transformation domain facilitates quick data processing. The fundamental purpose of a wavelet is to restrict both energy and time. The base functions are like very little waves. A image of the wavelet transform may be thought of as a foundation-function picture. It has both a time and a frequency resolution. The wavelet transform enables the study of signals or images at several resolutions.

### C. Fault Diagnosis using DT classifier

Decision Trees may be used for classification and regression in non-parametric supervised learning. "DT" is sometimes used interchangeably with "decision trees" (often reduced to "DTs"). This project will find and apply fundamental decision rules based on data attributes to build a model that can predict a target variable's value. Data features will be governed by these guidelines. The elucidation and implementation of straightforward decision-making guidelines are the means to this end. One way to think about it is as an example of something called a piecewise constant approximation, and a tree may serve as such an illustration.

This is shown as an example in the following graphic. As more layers are added to the tree, the criteria for making decisions get increasingly sophisticated, which simultaneously leads the model to become more accurate.

It is straightforward and not difficult to grasp the significance of what is being said. If one so desires, they are able to conjure up mental pictures of trees.

Requires minimum data preprocessing. When using alternative methods, it is often required to finish the phases of data normalization, which include the generation of dummy variables and the elimination of blank values. Be mindful, however, that missing value

support is not something that can be provided by this module. It simply does not have the capability to do so.

The logarithm of the amount of data points needed to train the tree determines the cost of utilizing it and making predictions. This cost is also known as the cost of using the tree. This is because additional data points were used during the training process of the tree.

Capable of simultaneously dealing with both numerical data and information pertaining to categories. Unfortunately, the version of scikit-learn that is currently available does not support categorical variables in any manner, shape, or form. The bulk of the time, alternative methods are developed specifically for the analysis of datasets that only include a single category of variable.

The great majority of the time, this is how things turn out. In order to get more information, please refer to the algorithm.

It is capable of coping with issues that have several possible outcomes.

### D. Algorithm flowchart-

The schematic of fault diagnosis approach is shown in figure 2, which you can get here. The explanation for each of the following stages included in the flowchart can be found below:

**Step 1:** The three-phase system in the MATLAB simulation, and the Cascaded H-Bridge (CHB) architecture is used for the simulation.

**Step 2:** involves generating voltage-current signals and creating open (OC) and short switch (SC) failure situations inside the CHB architecture.

**Step 3:** In the third step, the characteristics of the voltage-current signals that have been formed are extracted with the assistance of the wavelet transform.

**Stage 4:** The following step involves training the DecisionTree classifier in order to attain the highest possible level of accuracy in the training process.

**Stage 5:** In the fifth step of the process, which takes place during the testing phase, an unlabeled test case

is used as input for the trained DT classifier in order to locate and categorize the error. No fault is represented by the number "0," an open switch fault is represented by the number "1," and a short switch fault is represented by the number "2."

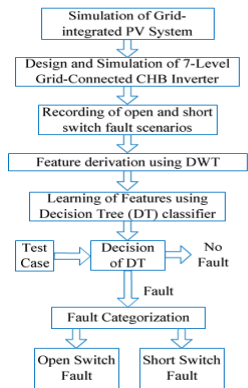

Figure 2: Flowchart of proposed algorithm.

### III. PERFORMANCE ANALYSIS

The performance of the proposed protection algorithm based on the joint framework of Discrete wavelet transform and Decision Tree classifier is examined in this part under a variety of switch failure situations that were constructed in the CHB inverter in three-phase system. Figure 3 shows a three-phase system which is integrated to the grid.

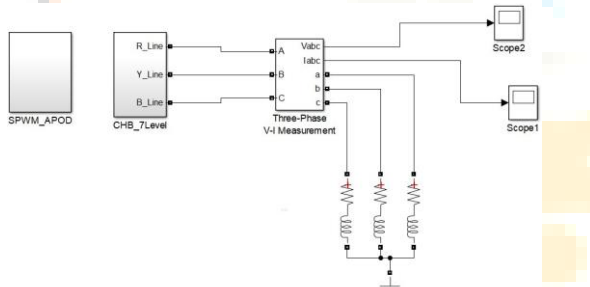

Figure 3: Simulink model of three-phase system with CHB Inverter.

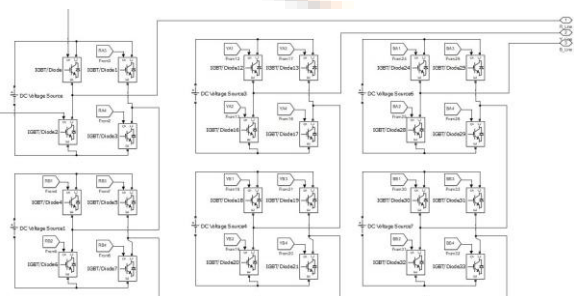

Figure 4: Detailed model of 7-level CHB inverter configuration.

The 7-level CHB multi-level inverter, seen in figure 4 above, is susceptible to errors when subjected to the high-frequency switching of power switches and complicated environmental circumstances. The majority of the problems with the inverter are caused by problems with the power switches. These problems might include both open-circuit faults and short-circuit faults in the power switches.

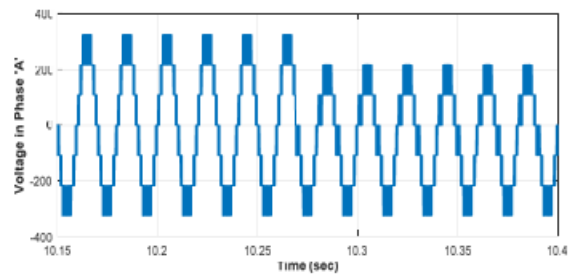

Figure 5: Voltage waveform of phase A due to short-switch fault in leg 1 of CHB Inverter at t=10.25 sec

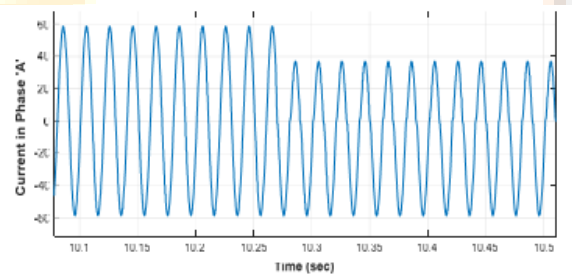

Figure 6: Current waveform of phase A due to short-switch fault in leg 1 of CHB Inverter at t=10.25 sec

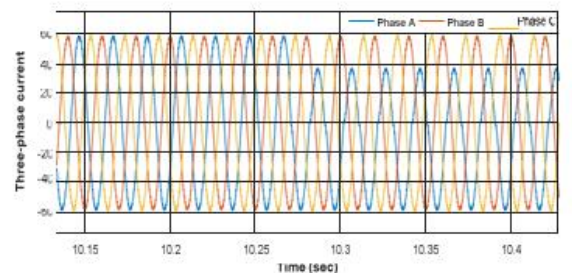

Figure 7: Three-phase Current waveform due to short-switch fault in phase 'A' of CHB Inverter at t=10.25 sec



The graphical representation of the voltage and current signals in Phase ‘A’ due to short-switch fault in leg 1 of the CHB inverter at  $t=10.25\text{sec}$ , has been depicted in figures 5 and 6 respectively. The three-phase current waveform is depicted in Figure 7. As observed, there is significant effect of the switch fault in phase A, which should be correctly identified and categorized for the reliable operation of the inverter.

Table 1: Performance of proposed DT based switch fault diagnosis scheme.

Cases	Faulty Leg	Faulty operation of Switch	Detection accuracy of DT (%)
1	Phase A	OC fault	99.2%
2			
3		SC fault	99.0%
4			
5	Phase B	OC fault	99.3%
6			
7		SC fault	98.8%
8			
9	Phase C	OC fault	98.9%
10			
11		SC fault	98.3%
12			
<b>Overall Performance</b>			<b>98.91%</b>

The performance of proposed technique has been analyzed and summarized in Table 1. The tabular representation of the obtained values are shown which determines the performance of proposed DT based fault diagnosis scheme for inverter switch fault. The performance of proposed algorithm is demonstrated in each leg of the CHB inverter. It can be observed that in all the legs of the CHB inverter, nearly similar performance is obtained. Thus, an overall accuracy rate of 98.91% is achieved.

#### IV. CONCLUSIONS

Depleting natural resources and rising fossil fuel and nuclear pollutants have boosted renewable energy. Engineers develop grid-connected power conversion systems. Multilevel inverters provide powerful solutions. Utility applications include renewable energy utility interface, control of voltage, VAR

compensation, and harmonic filtering in power systems use cascaded h-bridge multilevel inverters. This paper presents developing a mechanism for discovering and diagnosing switch problems in a grid-connected CHB inverter. The suggested technique uses Wavelet transform to extract features, then a Decision Tree classifier to identify and classify faults. Higher classification accuracy of suggested DT-based fault diagnostic method for diagnosing switch problem proves its usefulness.

#### REFERENCES

- [1]. Bose, B. K. (2013). Global energy scenario and impact of power electronics in 21<sup>st</sup> century. *IEEE Trans. on Ind. Electron.*, 60(7):2638-2651.
- [2]. Kouro, S., Malinowski, M., Gopakumar, K., Pou, J., Franquelo, L. G., Wu, B., Rodriguez, J., Perez, M. A., and Leon, J. I. (2010). Recent advances in power electronics for renewable energy systems: A survey. *IEEE Trans. on Ind. Electron.*, 57(5):1108-1120.
- [3]. Blaabjerg, F., Chen, Z., and Kjaer, S. B. (2004). Power electronics as efficient interface in dispersed power generation systems. *IEEE Trans. on Power Electron.*, 19(5):1184-1194.
- [4]. Carrasco, J. M., Franquelo, L. G., Bialasiewicz, J. T., Galvan, E., PortilloGuisado, R. C., Prats, M. M., Leon, J. I., and Moreno-Alfonso, N. (2006). Power-electronic systems for the grid integration of renewable energy sources: A survey. *IEEE Trans. on Ind. Electron.*, 53(4):1002-1016.
- [5]. Romero-Cadaval, E., Spagnuolo, G., Franquelo, L. G., Ramos-Paja, C. A., Suntio, T., and Xiao, W. M. (2013). Grid-connected photovoltaic generation plants: Components and operation. *IEEE Ind. Electron. Mag.*, 7(3):6-20.
- [6]. Kouro, S., Leon, J. I., Vinnikov, D., and Franquelo, L. G. (2015). Grid-connected photovoltaic systems: An overview of recent research and emerging pv converter technology. *IEEE Ind. Electron. Mag.*, 9(1):47-61.
- [7]. Kjaer, S. B., Pedersen, J. K., and Blaabjerg, F. (2005). A review of single-phase grid-connected inverters for photovoltaic modules. *IEEE Tran. on Ind. Appl.*, 41(5):1292-1306.
- [8]. Kouro, S., Malinowski, M., Gopakumar, K., Pou, J., Franquelo, L. G., Wu, B., Rodriguez, J., Perez, M. A., and Leon, J. I. (2010). Recent advances

and industrial applications of multilevel converters. *IEEE Trans. Ind. Electron.*, 57(8):2553-2580.

[9]. Marchesoni, M., Mazzucchelli, M., and Tenconi, S. (1990). A nonconventional power converter for plasma stabilization. *IEEE Trans. Power Electron.*, 5(2):212{219.

[10]. Mueller, O. and Park, J. (1994). Quasi-linear igbt inverter topologies. In *Applied Power Electronics Conference and Exposition, 1994. APEC'94. Conference Proceedings 1994., Ninth Annual*, pages 253{259. IEEE.

[11]. Lipo, T. A. and Manjrekar, M. D. (1999). Hybrid topology for multilevel power conversion. US Patent 6,005,788.

[12]. Steimer, P. K. and Manjrekar, M. D. (2001). Practical medium voltage converter topologies for high power applications. In *Industry Applications Conference, 2001. Thirty-Sixth IAS Annual Meeting. Conference Record of the 2001 IEEE*, volume 3, pages 1723{1730. IEEE.

[13]. Damiano, A., Fracchia, M., Marchesoni, M., and Marongiu, I. (1997). A new approach in multilevel power conversion. In *European conference on power electronics and applications*, volume 4, pages 4{216.

[14]. Chen, D., Liu, Y. and Zhang, S., 2019. Open-circuit fault diagnosis method for the T-type inverter based on analysis of the switched bridge voltage. *IET Power Electronics*, 12(2), pp.295-302.

[15]. James J. Q. Yu , Member, IEEE, YunheHou, Intelligent Fault Detection Scheme for Microgrids With Wavelet-Based Deep Neural Networks, *IEEE TRANSACTIONS ON SMART GRID*, VOL. 10, NO. 2, MARCH 2019.

[16]. Debi Prasad Mishra, Subhransu Ranjan Samantaray, Senior Member, IEEE, and GezaJoos, Fellow, IEEE, A Combined Wavelet and Data-Mining Based Intelligent Protection Scheme for Microgrid, 1949-3053 © 2015 IEEE.