

AC-DC High Step UP Converter with Minimum Switched Capacitor: A Critical Review

Preeti Tapal

Department of Electrical Engineering

Oriental University, Indore

Pree.tapal09@gmail.com

Abstract- This paper presents a single-stage circuit topology consisting of the association of a full-bridge isolated dc-dc converter and two input inductors and two input diodes connected to the mains network, in order to obtain an isolated ac/dc switch mode power supply, with sinusoidal input current. The proposed topology does not use an input bridge rectifier, common in similar applications. The current in the two input inductors can therefore, flow in both directions. Consequently, the proposed topology equally distributes the current by the four-bridge transistors that provide four input parallel boost power factor correctors (PFCs). The use of the four bridges permitting the accurate simultaneous regulation of output voltage and input current is hereby described.

Keywords— Full-bridge converters, Input current shaping, low-distortion input current, single-stage power factor correctors (PFCs).

1. INTRODUCTION

AC to DC converters is widely used in many offline power supplies like SMPS. We should develop more efficient, smaller size and cheap ac to dc converters. Multi stage converters introduce a highly distorted input current, resulting in a large amount of odd harmonics and a low power factor. In order to reduce input current distortions and to improve the power factor need an additional ac to dc conversion stage of power factor correction (PFC) is should be clubbed in front of the dc to dc converter. It leads to provide a two-stage approach that includes a PFC stage to rebuild the input current into a sinusoidal shape and a dc to dc conversion stage for the regulation of output voltage. Two stage converters have better performance than other multi stage converters but it requires more circuit components and two power-conversions [4], resulting in higher component cost and lower efficiency. To overcome the drawbacks of the two-stage approach, single- stage ac/dc converters have been developed by single stage PFC circuit with dc/dc converter. By sharing one or more active switches and the control the overall circuit thereby reduced size. In spite of these good qualities this converters leads to hard-switching operation which results in low circuit efficiency and limits the output power rating. Application of higher switching frequency to realize smaller magnetic components and capacitors gives better performance. In order to reduce switching

losses, various auxiliary circuits and wide ranges of snubbers are required. It will add the circuit complexity and overall component cost. So we require soft-switching characteristics by using resonant topologies. We need to include resonant tanks in the converters to create oscillatory voltage or current waveforms so that zero voltage switching (ZVS) or zero current switching (ZCS) conditions can be created for the power switches. The resonant transition converters are more efficient family of soft switching topologies. They include the low switching loss characteristics of the resonant converters and the constant frequency and low conduction loss characteristics of the PWM converters under discontinuous mode. These are typically square wave converters during their mode of operations, except during the resonant transitions.

2. LITERATURE REVIEW

Many input current wave shaping methods have been proposed to overcome above disadvantages, which can broadly classify as active, passive and hybrid methods. In the past, designers have used three passive wave shaping methods to improve the input power factor and reduce Total Harmonic Distortion (THD) of conventional ac-to-dc rectifiers [1]. Many passive techniques (i.e. circuits using only inductors and capacitor) are available to improve power factor PF and reduce the levels of harmonics for single phase rectifier, including the connection of series supply reactor, tuned series harmonic filter, tuned parallel harmonic filter. In these methods the power factor is

improved and harmonic distortion is reduced in comparison with conventional topology. Among the passive wave shaping methods proposed earlier, the novel method proposed by P. D. Ziogas [2] in 1990 is superior to others in reducing the input current harmonics and improving the input power factor. The novel method can efficiently improve the power factor. However, further improvement of the input power factor is difficult to achieve, and the input current disadvantage of the novel topology. This method is named as improved passive wave shaping method by Yanchao in 2001 [3]. M.A. Khan [4] designed a single phase rectifier with switching on AC side for high power factor and low total harmonic distortion in 2007. This method uses a single MOSFET switch on the ac side to provide alternative path for input current to flow and hence make it continuous. The rectifier is connected to the ac mains through a series combination of inductor and capacitor, which keeps the input current smooth and in phase with the supply voltage. The

Circuit proposed for current shaping consists of a Boost converter connected to the line and a Buck converter connected to the output capacitor [5]. Gun Woo Moon et al. proposed a new zero current switched (ZCS) high power factor rectifier for power factor correction in 2008. The proposed single phase rectifier enables zero current switching operation of all the power devices allowing the circuit to operate at high switching frequencies and high power levels. With the proposed control technique, unity power factor and greatly reduced line current harmonics can be obtained [6]. In 2008, Do-Hyun Jang et al. proposed Asymmetrical Pulse Width Modulated (APWM) control technique for the ac choppers to improve the input power factor. The switching function for the proposed chopper is derived. The proposed strategy is simplified to an approximate APWM which can be realized by the analog circuit. The proposed converter operates in discontinuous conduction mode, and requires only a single- control loop. The number of switches (one or two) is a function of the gain of the converter. The input currents of the converter have a little ripple, and the output voltage is free of low order harmonic content. The output stage can be isolated [7]. Taniguchi, K. et al. proposed a Soft-switching three-phase PWM-PFC converter in 2009. To achieve the zero voltage

switching, the proposed converter is constructed by using a resonant network in parallel with the switch of the conventional PWM converter. In this scheme the PWM converter achieves the soft-switching for all switching devices without increasing their voltage and current stresses [8]. In 1998 Hwang, J et al. proposed a green-mode function is to improve the efficiency of a pre / post-switching regulator at light loads. In 2010 Chung, H.S.H et al. presented the use of fuzzy logic to derive a practical control scheme for Boost rectifier with active power factor correction. The methodology integrates fuzzy logic control technique in the feedback path and linear programming rule on controlling the duty cycle of the switch for shaping the input current waveform. In 2011 Byoung-Kuk Lee et proposed a novel direct current controlled PWM. The operational principle of the four-switch BLDC motor drive and the developed control scheme are theoretically analyzed and the performance is demonstrated by both simulation and experimental results [9]. In 2012 Tao Qi et al. presented a new current control method for dual-Boost single-phase power-factor-correction (PFC) converters. The proposed current control method is based on sensing of the dc output current, which can be easily accomplished by using a sensing resistor inserted on the negative rail of the dc output. In 2013 Marcelle Merhy et al. presented a nonlinear model from one point of observation to the next. Analysis of this model shows that chaos and bifurcations may occur along with the changing values of some system parameters. In 2014 Hongbo Ma et al. presented in 2014 a novel PFC topology is proposed by inserting the valley fill circuit in the SEPIC- derived converter, which can reduce the voltage stress of storage capacitor and output diode to half under the same power factor condition. This valley fill SEPIC-derived PFC topology is then proposed for LED lighting application [10]. In 2015 Yen-Shin Lai presented a random switching method Which changes switching frequency while retaining constant sampling frequency. The proposed method can effectively reduce magnitude of PWM harmonics. Experimental results derived from an FPGA-based controller are presented for confirmation.

3. SINGLE STAGE FULL BRIDGE CONVERTER

These topologies can perform input current wave shaping and output voltage control, simultaneously, without using any additional transistors. However,

these topologies are not optimized in terms of additional components and current distribution in the bridge transistors. For example, in the topologies presented, only two parallel input boost converters are provided using the low-side transistors, which leads to asymmetrical current distribution in the bridge transistors causing, in these transistors, a high current stress. An input bridge rectifier is also needed for these topologies. For the topologies proposed, only one input inductor is used, but this inductor and the two low-side transistors have to support the maximum input current. On the other hand, the topology presented uses two inductors for half of the maximum input current, which means that, each low side boost transistor needs only to support half of the maximum input current, thereby reducing the current stress in these transistors. However, the topology uses six additional diodes, thus increasing the cost and reducing the efficiency. In an attempt to solve the referred problems, this project presents an optimized and improved single stage full-bridge ac/dc converter, where the input bridge rectifier was replaced by two rectifier diodes.

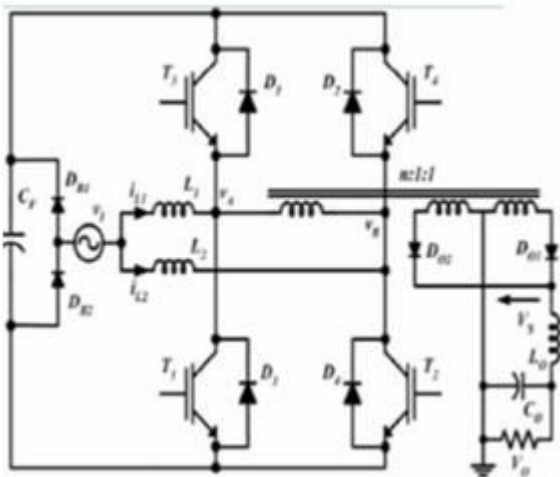

Figure 1: High-efficiency full-bridge single stage topology

This fact obviously allows, by itself, a slight improvement in the converter efficiency. In addition, it also guarantees the improvement of the converter by performing four input boosts, to accomplish the PFC function, instead of two as it is common in other existing topologies. This way, the operation of the proposed topology will result symmetric, with all the inherent advantages in terms of current and voltage switches' stress reduction. Full analysis and design

criteria are completely described in this project.

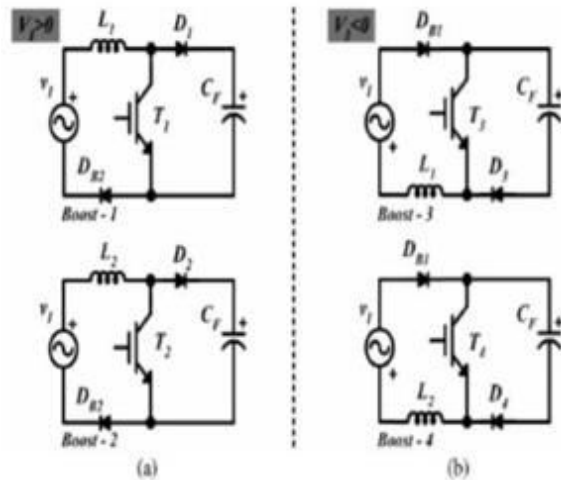

Figure 2: Four boost converters provided by the topology

This fact obviously allows, by itself, a slight improvement in the converter efficiency. In addition, it also guarantees the improvement of the converter by performing four input boosts, to accomplish the PFC function (see Fig. 2), instead of two as it is common in other existing topologies. This way, the operation of the proposed topology will result symmetric, with all the inherent advantages in terms of current and voltage switches' stress reduction.

4. AC-DC CONVERTER

The applications of high step up AC-DC full bridge converters are intensity discharge lamp ballasts for automobile headlamps, fuel-cell energy conversion systems, solar-cell energy conversion systems, battery backup systems for uninterruptible power supplies (UPS) etc. Here proposing a new single stage high step up AC-DC full bridge converter topology that features simple power and control circuitry. PWM control is used to control the switching action of the switches. Performance of the proposed converter under steady state analysis in continuous conduction mode is discussed in detail. Emphasis is given on demonstrating the operating principle, modes of operation, and derives circuit equation. The contents of this paper includes Proposal of a new single stage high step up AC-DC full bridge converter topology that features simple power and control circuitry.

(1) Full Bridge AC-DC converter (FB) which consists of four MOSFET switches that are built-in anti-parallel

diodes

- (2) Performing the steady state analysis of the proposed converter in continuous mode of operation.
- (3) Analyzing the open loop and closed loop simulation results of AC-DC full bridge converter.

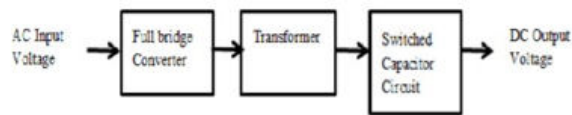

Figure 3: Block Diagram of Proposed AC-DC Converter

The block diagram of AC-DC converter is shown in Figure 3, gives a constant ac input voltage to the MOSFET full bridge circuit, and that output is given to the primary side of the coupled inductor with low magnetizing inductance. The secondary side of the coupled inductor is fed to the switched capacitor circuit and obtains high voltage dc output voltage. Driver circuit is essential due for giving power to control signal for driving MOSFET.

5. PROPOSED METHODOLOGY

The circuit is composed of sinusoidal mains voltage V_{in} , four switches S_1, S_2, S_3 and S_4 , coupled inductors N_p and N_s , diodes $D_a, D_b, D_c, D_d, D_1, D_2, D_3$ and D_4 , two capacitors C_1 and C_2 , two secondary diodes D_5 and D_6 , output diode D_o , and output capacitor C_o and load R_o are shown in Figure 3. The turn's ratio of the coupled inductor n is equal to N_s/N_p . However a known delay is introduced between turn-off of one switch and the turn on of the other switch of the same leg to avoid simultaneous conduction of any two switches from the same leg. The gate drives of both legs, S_1, S_4 or S_2, S_3 are complementary.

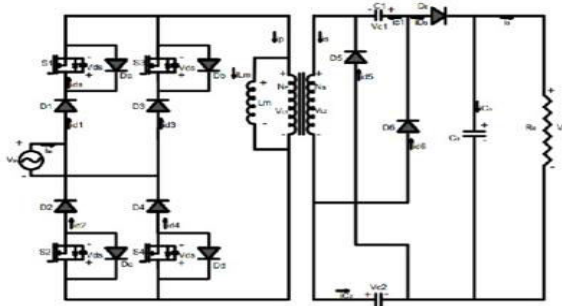

Figure 4: Circuit of Proposed Converter using Switching Capacitor Technique

The use of switches with low resistance $R_{DS(ON)}$ is to reduce the conduction loss of the entire circuit. The parallel charged current is not inflow. The proposed converter utilized the concept of switched-capacitor technique i.e., two capacitors can be charged in parallel and discharged in series to achieve a high step-up gain. Thus, capacitors on the secondary sides C_1 and C_2 are charged in parallel and are discharged in series by the switches are turned OFF and turned ON is shown in Figure 4. Duty cycle D is defined as the time when S_1 and S_2 are both ON during the first half cycle or when S_3 and S_4 are both ON during the second half cycle. The principle is that, when the switches are turned ON, the energy stored in magnetic inductor and the coupled-inductor-induced voltage on the secondary and the induced voltage makes V_{L2}, V_{C1} and V_{C2} release energy to the output in series.

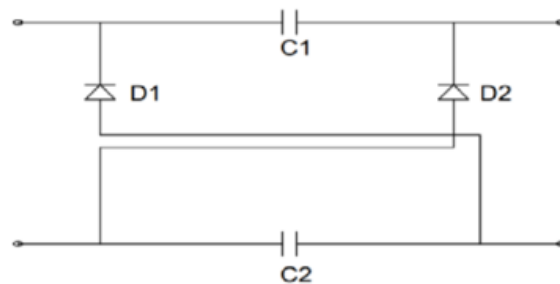

Figure 5: Switched Capacitor Technique

The features of proposed AC-DC converter are:

1. Reduced switch voltage ratings.
2. The applicability is for low-medium power ranges.
3. Light converter and easy control circuitry.
4. It has only lesser components making it less weight, low cost and compact

So many applications are developed on the basis of full bridge converter. The full bridge converter has significant role in power electronics and drives application compares to other power electronic converters. High voltage dc power supplies have widely applied in the industries, science, military, X-ray systems, dust-filtering, insulating test, and electrostatic coating etc.

6. CONCLUSIONS

In this paper, after the study of methods used to improve the voltage gain in DC-DC converter and AC-DC converters in the early literature, a new single stage AC-DC converter has been proposed based on the idea

of switched capacitor technique, this paper proposes a novel single stage high step up full bridge AC-DC converter based on the concept of switched capacitor topology, implemented in high step up DC- DC converter. In switched capacitor technique, capacitors on secondary side are charged in parallel during the switch-OFF period, by the energy stored in the coupled inductor, and are discharged series during the switch-ON period to achieve a high step-up voltage gain. The proposed AC-DC full bridge converter converts the input AC voltage into DC and boost with a high voltage gain in single stage. For high voltage gain AC-DC converters many techniques are proposed in literature. In this work, switched capacitor technique is used in AC-DC converter is a novel method for attaining high voltage gain.

REFERENCES

- [1] K. C. Iseng and T. I. Liang, "Analysis of integrated boost- flyback step up converter," *Processing Inst. Elect. Eng. Elect. Power Appl.*, vol. 152, no. 2, pp. 217-225, Mar. 2005.
- [2] R. J. Wai and R. Y. Ouan, "High step-up converter with coupled inductor," *IEEE Trans. Power Electron.* vol. 20, no. 5, pp. 1025- 1035, Sep. 2005.
- [3] R. J. Wai, C. Y. Lin, C. Y. Lin, R. Y. Ouan, and Y. R. Chang, "High efficiency power conversion system for kilowatt-level stand-alone generation unit with low input voltage," *IEEE Trans. Ind. Electron.* vol. 55, no. 10, pp. 3702- 3714, Oct. 2008.
- [4] L. S. Yang, T. J. Liang, and J. F. Chen, "Transformer-less dc- dc converter with high voltage gain," *IEEE Trans. Ind. Electron.* vol. 56, no. 8, pp. 3144- 3152, Aug. 2009.
- [5] F. L. Luo, "Six self-lift dc- dc converters, voltage lift technique," *IEEE Trans. Ind. Electron.* vol. 48, no. 6, pp. 1268- 1272, Dec. 2001.
- [6] F. L. Luo and H. Ye, "Positive output super-lift converters," *IEEE Trans. Power Electron.* vol. 18, no. 1, pp. 105- 113, Jan. 2003.
- [7] T. F. Wu, Y. S. Lai, I. C. Hung, and Y. M. Chen, "Boost converter with coupled inductors and buck-boost type of active clamp," *IEEE Trans. Ind. Electron.* vol. 55, no. 1, pp. 154-162, Jan. 2008.
- [8] R. I. Wai and R. Y. Ouan, "High step-up converter with coupled inductor," *IEEE Trans. Power Electron.* vol. 20, no. 5, pp. 1025- 1035, Sep. 2005.
- [9] T. F. Wu, Y. S. Lai, J. C. Hung, and Y. M. Chen, "Boost converter with coupled inductors and buck-boost type of active clamp," *IEEE Trans. Ind. Electron.* vol. 55, no. 1, pp. 154-162, Jan. 2008.
- [10] Revathi V I, Muhammedali Shafeeque K " Closed Loop Operation of High Boost OC-OC Converter Operating in CCM Mode" in *Proc. International Journal of Scientific Engineering and Applied Science (USEAS) - vol.1, no.4, June 2015.*
- [11] Revathi V I , Muhammedali Shafeeque K "A Novel High Boost OC-OC Converter for Oistributed Generation System" *IEEE ICCCS Conference, 2014*
- [12] Yi-Ping Hsieh, Jiann-Fuh Chen, Isornng-Juu Liang, and Lung-Sheng Yang, " Novel High Step-Up OC- OC Converter with Coupled-Inductor and Switched-Capacitor Techniques", *IEEE Trans. Ind. Electron.*, vol. 59, no. 2, Feb,2012.